

ECU pins are listed as model A1 (A2/B1/B2)

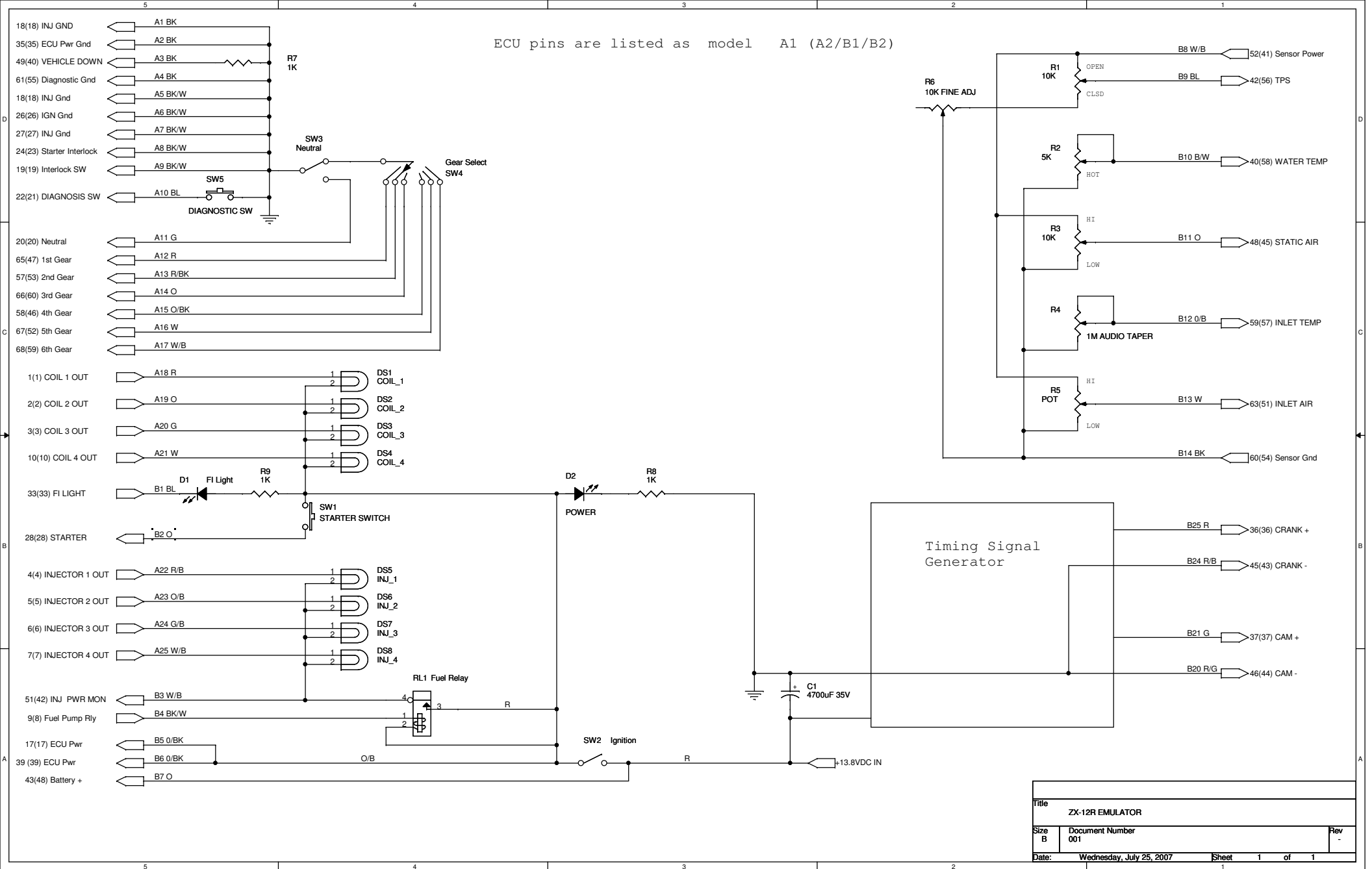

Title		
ZX-12R EMULATOR		
Size	Document Number	Rev
B	001	.
Date:	Wednesday, July 25, 2007	Sheet 1 of 1